

FISHER®

FISHER MANUFACTURING COMPANY TOLL FREE: 800-421-6162 - FAX: 800-832-8238
customer@fisherfaucets.com - www.fisherfaucets.com

PRODUCT NAME:

ウォール・プレリンユニット(ロータイプ)

Customer/Wholesaler:	Date:	Job Name:	Model Specified: 22100-440	Quantity:
Contractor:	Architect/Engineer:			

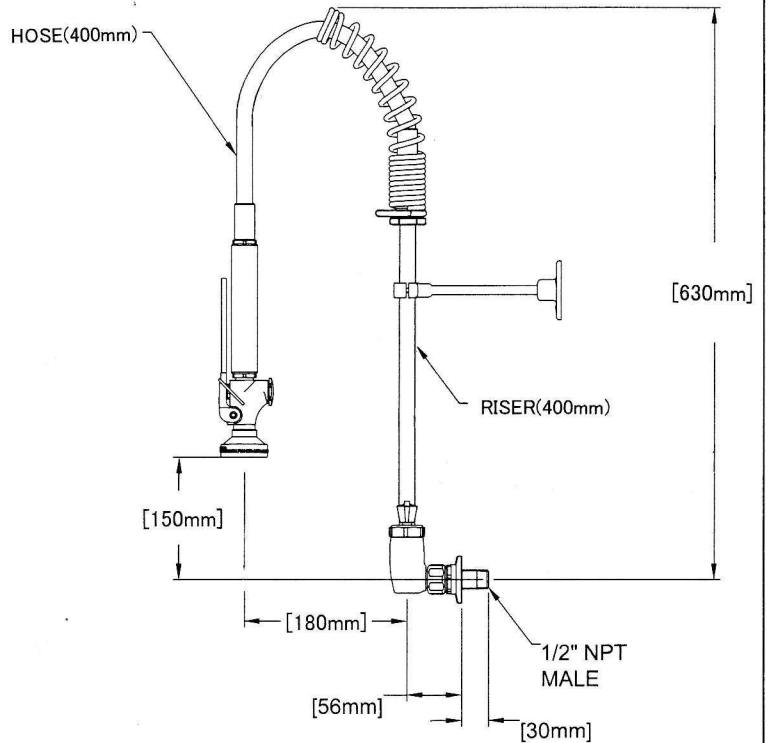
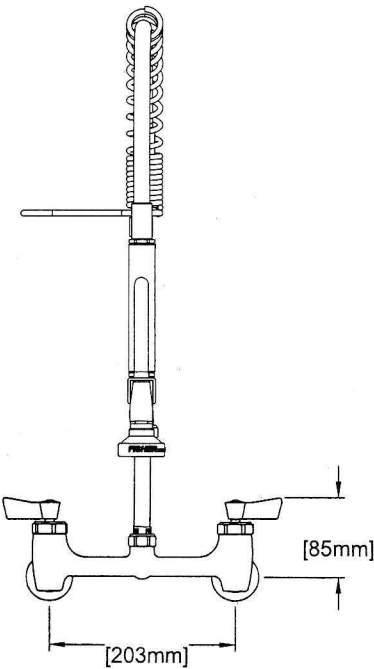
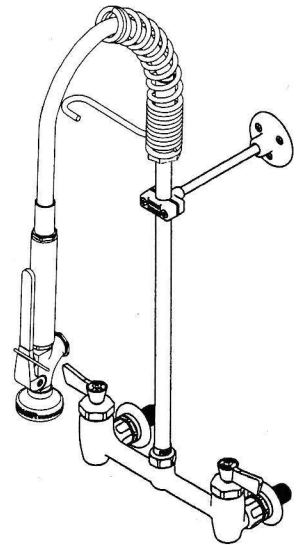
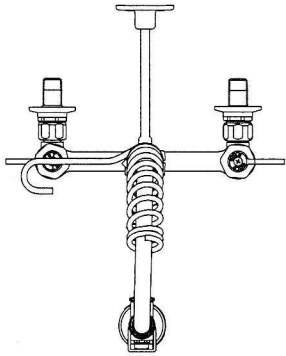

PRODUCT COMPLIANCE:
ASME A112.18.1 / CSA B125.1
NSF 61 - Section 9
NSF 372 (Low Lead Content)
2019 DOE PRSV - Class II

Drawn: LC	Checked: EM	Approved: LC	Date: 02/29/24	Sheet:
-----------	-------------	--------------	----------------	--------

SPEC: PRCB-SQA-8BSLL