

FISHER

FISHER MANUFACTURING COMPANY TOLL FREE: 800-421-6162 - FAX: 800-832-8238
customer@fisherfaucets.com - www.fisherfaucets.com

PRODUCT NAME:

REEL RINSE WHITE EXP UC 20 FT US

Customer/Wholesaler:	Date:	Job Name:	Model Specified: 29842	Quantity:
Contractor:	Architect/Engineer:			

SPEC. RRCI-CUT-XX

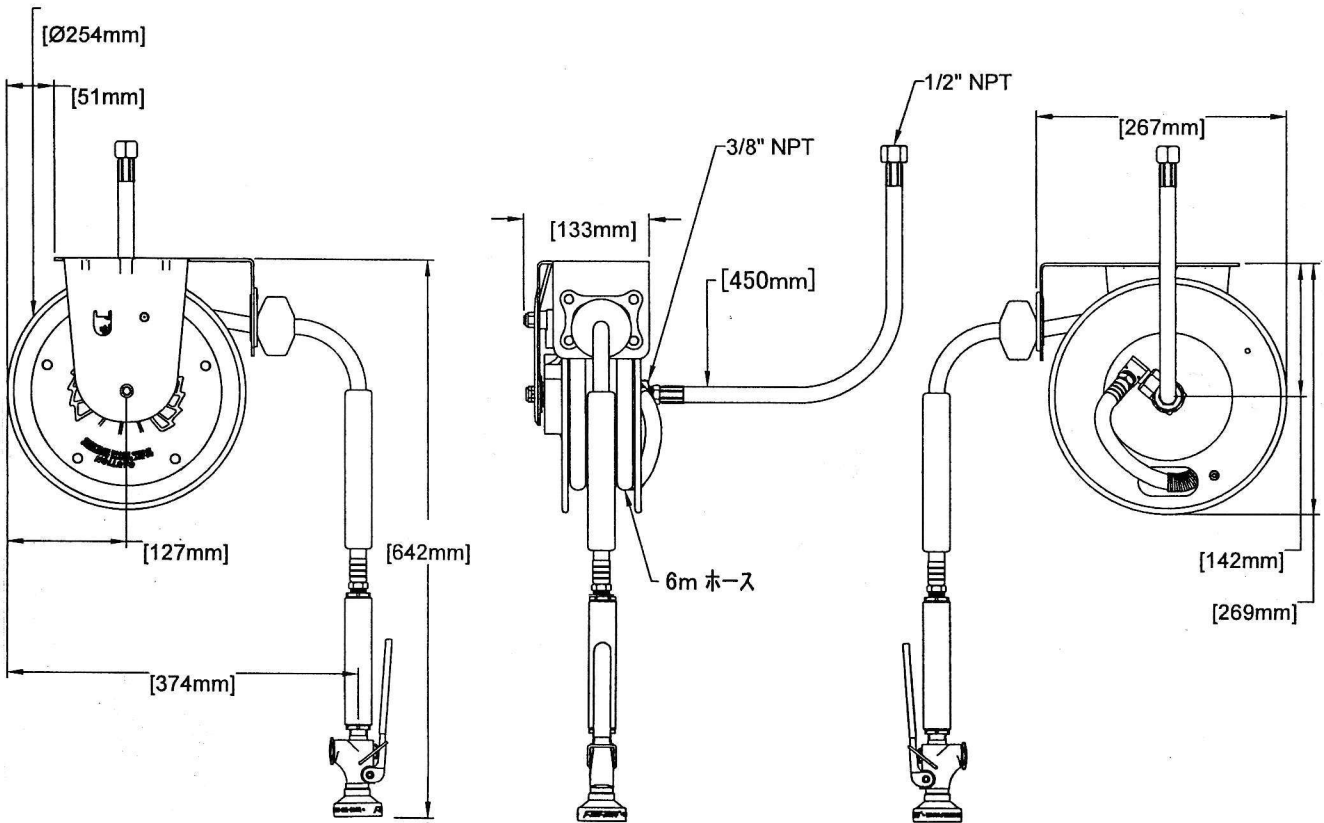

PRODUCT SPECIFICATIONS: CAFE REEL RINSE, EXPOSED WHITE POWDER COATED STEEL, UNDER COUNTER MOUNT, 20' HOSE X 3/8" ID, 2.65 GPM @ 80 PSI UTILITY SPRAY VALVE, 18" INLET HOSE X 3/8" ID, 1/2" NPT FEMALE INLET

PRODUCT COMPLIANCE:
NSF 61 EXEMPT:
(NON-POTABLE)
2019 DOE PRSV:
NON-COMPLIANT

Drawn: LC	Checked: EM	Approved: LC	Date: 05/19/25	Sheet:
-----------	-------------	--------------	----------------	--------

FISHER

FISHER MANUFACTURING COMPANY TOLL FREE: 800-421-6162 - FAX: 800-832-8238
customer@fisherfaucets.com - www.fisherfaucets.com

PRODUCT NAME:

29842 用マウンティングプレート

Customer/Wholesaler:	Date:	Job Name:	Model Specified:	Quantity:
----------------------	-------	-----------	------------------	-----------

Contractor:	Architect/Engineer:
-------------	---------------------

TOP VIEW (上から見た図面)

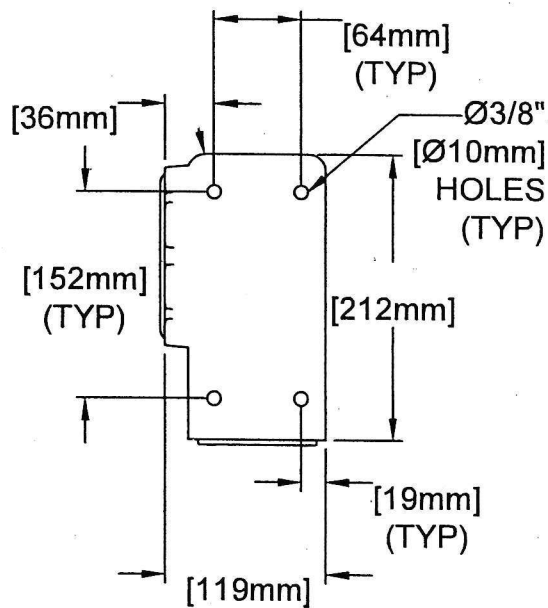

PRODUCT COMPLIANCE:
NSF 61 EXEMPT:
(NON-POTABLE)
2019 DOE PRSV:
NON-COMPLIANT